

*Staurolite twinning.*

(With Plates V-VI.)

By VERNON J. HURST,<sup>1</sup> B.S., M.S., Ph.D., and

J. D. H. DONNAY, E.M., Ph.D.

The Johns Hopkins University, Baltimore 18, Maryland, U.S.A.

and GABRIELLE DONNAY, B.A., Ph.D.

Geophysical Laboratory, Carnegie Institution of Washington,  
Washington, D.C., U.S.A.

[Taken as read 26 January 1956.]

*Summary.*- The space group  $Ccmm$  of the accepted staurolite structure (7-82:16-52:5-63 kX 0-473:1:0-341, Náray-Szabó, 1929) is a pseudo-space group; the true one has no  $c$  glide plane. Staurolite is monoclinic pseudo-orthorhombic, as shown optically by horizontal dispersion and morphologically by unequal developments of forms  $r(201)$  and  $r'(201)$ . It has variable cell dimensions, 7-83-7-95:16-50-16-82:5-62-5-71 Å., constant  $\beta = 90^\circ \pm 3'$ , aspect  $C^*$ , and probable space group  $C2/m$  (negative pyroelectric test). This leads to the prediction of a new type of twin, 'by high order merohedry', a penetration twin that simulates an orthorhombic single crystal. It is known (Friedel, 1922) that the  $90^\circ$ -cross can be accounted for by two different twin laws and the  $60^\circ$ -cross by five. The twin operations are respectively the pseudo-symmetry operations of a pseudo-tetragonal cell, obtained by transformation 010/003/100, and those of Mallard's pseudo-cube, resulting from transformation 013/013/300. By precession methods more than one twin law is established for each type of cross: both laws  $[100]_{90^\circ}$  and  $[013]_{130^\circ}$  are found for  $90^\circ$ -crosses;  $[313]_{130^\circ}$  and  $[102]_{120^\circ}$ , for  $60^\circ$ -crosses.

THE question of the staurolite twin laws has never been answered satisfactorily because of the poor quality of the morphological measurements. The assumption has been that the  $90^\circ$ -cross and the  $60^\circ$ -cross should each be defined by a single twin law. We set out to check this assumption by means of Buerger's precession X-ray camera (1944), which can be used to yield accurate goniometric data. When the morphological analysis gave a space group different from that in the literature, we had to re-examine the symmetry of staurolite. We noted the variations of cell dimensions with composition, for these could be expected to affect twinning.

<sup>1</sup> Present address: Department of Mines, Mining, and Geology, 425 State Capitol, Atlanta, Georgia, U.S.A.

The material studied consists mainly of about 2100 specimens from Hackney's Farm, near Blue Ridge, Fannin County, Georgia, 1800 of which were provided by the Georgia Department of Mines, Mining, and Geology and 300 by Mr. Gilbert Withers, of Atlanta, Georgia. Also examined were: (1) other specimens from Fannin County; (2) a single crystal from Barrow County, Georgia; (3) material from Ducktown, Tennessee; (4) one specimen from Namib, Africa, U.S. Nat. Museum No. 8642; (5) one specimen from Alpe Sponda, Pizzo Forno, given to us by Dr. Hans Eugster of the Geophysical Laboratory (according to whom this locality is often referred to erroneously as Monte Campione or as St. Gotthard).

In this paper all symbols refer to the structural cell, with axial ratios  $a:b:c = 0.473:1:0.341$ , and  $\beta$  equal to  $90^\circ$  within limits of error.

#### *The symmetry of staurolite.*

In the past staurolite has been considered orthorhombic and holohedral. The forms reported in Goldschmidt's *Atlas* (vol. 8, 1922) can be listed as follows, in order of decreasing frequency: (1) Most common:  $m(110)$ ,  $b(010)$ ,  $c(001)$ ; (2) Common:  $r(201)$ ; (3) Uncommon:  $q(021)$ ,  $s(111)$ ,  $a(100)$ ,  $f(101)$ ,  $l(041)$ ,  $\gamma(401)$ ,  $\beta(103)$ ,  $\alpha(105)$ . Biswas (1928) reported  $q$ —as a new form—on three specimens from India. Forms  $\gamma$ ,  $\beta$ , and  $\alpha$  were reported only by Weiss (1901, in Goldschmidt). Our material shows only  $m$ ,  $b$ ,  $c$ , and  $r$ . Fifteen crystals from Hackney's Farm, measured on the Terpstra two-circle goniometer, yield the angles  $bm = 64^\circ 40'$  (average of 45 measurements, ranging from  $64^\circ 21'$  to  $65^\circ 1'$ ) and  $cr = 55^\circ 14'$  (average of 28 measurements, ranging from  $54^\circ 42'$  to  $55^\circ 38'$ ). They give the axial ratios  $a:b:c = 0.473:1:0.341$ , in agreement with previous values.

These meagre morphological data (fig. 1) can be used to determine the space group that best expresses the Generalized Law of Bravais (Donnay and Harker, 1937; Donnay, 1947). According to the morphological analysis (fig. 2),  $s$  must be taken as unit form (111) and the morphological aspect is  $C^{***}$  with possible space groups  $Cmmm$ ,  $C222$ ,  $C2mm$ ,  $Cm2m$ , and  $Cmm2$  (see Appendix). This result conflicts with the space group  $Ccmm$  previously determined by X-rays (Cardoso, 1928; Naray-Szabo, 1929). It is compatible with monoclinic as well as orthorhombic symmetry, and as we found no evidence against the presence of a centre of symmetry—staurolite gave us a negative pyroelectric test—the space group indicated by the relative frequencies of forms is either  $Cmmm$  or  $C2/m$ .

Morphological evidence, however, points towards monoclinic symmetry, since the four *r* faces are commonly unequal in size, apparently forming two pinacoids. This observation is not on record in the literature, yet in many instances only one pinacoid is to be seen. The angular

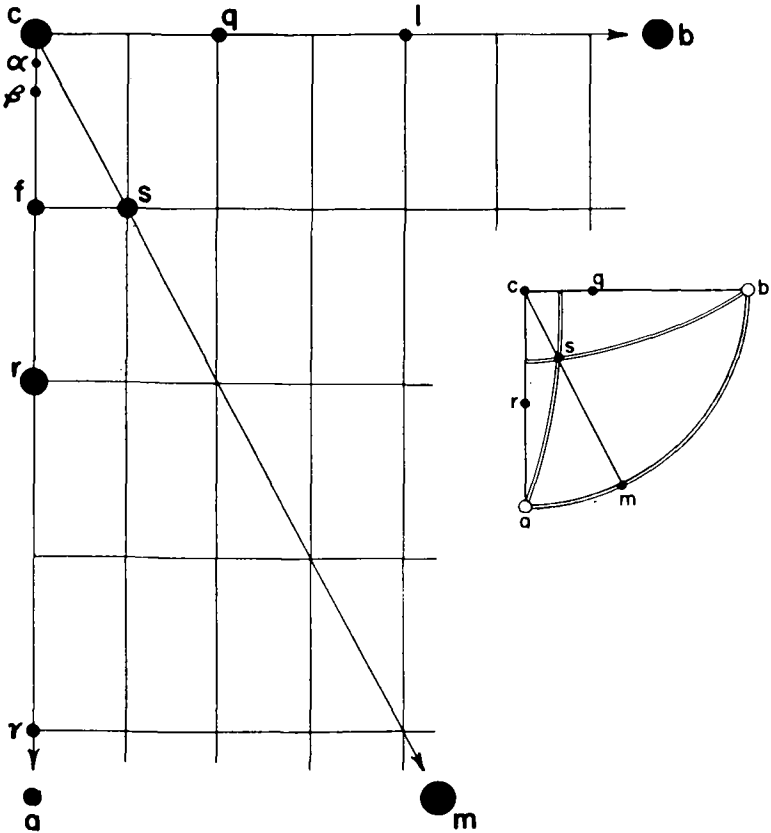

FIG. 1. Gnomonic projection of staurolite, radius of projection 3.3 cm. Only one octant is shown. The relative sizes of the poles roughly indicate the relative frequencies of the corresponding forms. The small stereographic projection summarizes the morphological development of aspect  $C^{***}$ .

measurements are too crude to tell the two pinacoids apart. Let the larger pinacoid be  $r(201)$  and the smaller  $r'(201)$ . We found  $cr = 55^\circ 8'$  (average of 6 values,  $54^\circ 54'$  to  $55^\circ 14'$ ) and  $cr' = 55^\circ 4'$  (average of 4 values,  $54^\circ 40'$  to  $55^\circ 38'$ ).

The evidence provided by X-ray diffraction is completely in favour of orthorhombic symmetry. No deviation from it can be detected on precession photographs taken at room temperature, either as to the positions or the intensities of the spots.

Optical measurements were made on plates cut from the *Alpe Sponda*

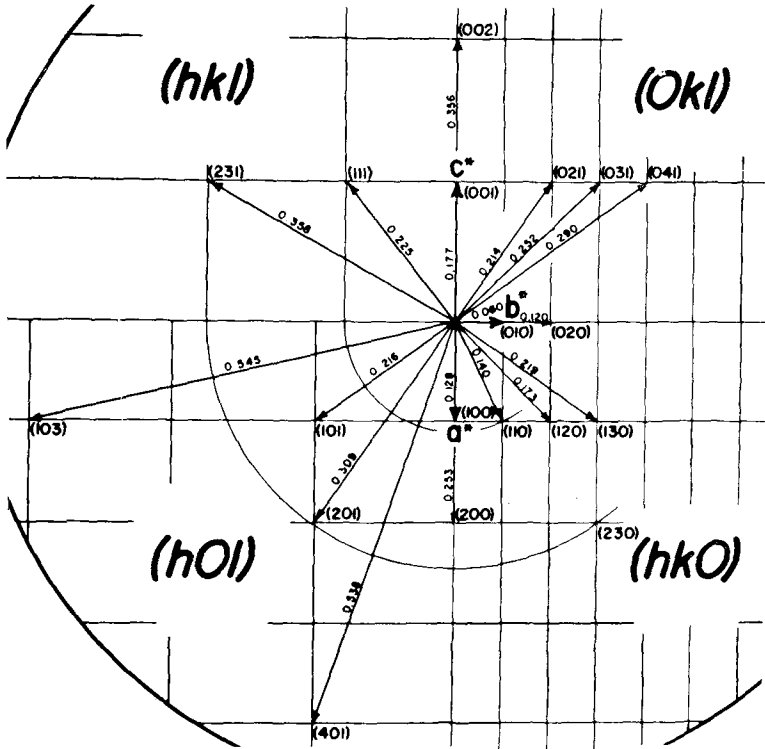

FIG. 2. Graphical determination of the lengths of reciprocal lattice vectors. The primitive translations  $a^*$ ,  $b^*$ ,  $c^*$  correspond to the choice of  $s$  as (111). All vector lengths are shown in  $\text{\AA}^{-1}$  for future reference, but this can be thought of as an arbitrary scale. For the purpose of morphological analysis, relative lengths obtained by goniometry can be used:  $a^*:b^*:c^* = 1/a:1/b:1/c$ .

specimen, as the Georgia specimens contain too many mineral inclusions. A plate cut parallel to  $c(001)$  gave  $\alpha$  1.739 and  $\beta$  1.744; another plate, cut parallel to  $b(010)$ , gave  $\gamma$  1.749 (all values  $\pm 0.003$ ; in yellow light,  $\lambda = 5890 \text{\AA}$ ). Dispersion was observed on two plates, about 0.4 mm. thick, perpendicular to the  $c$ -axis. The measurements were made on the

universal stage, with glass hemispheres of index 1.649 (checked to be free from strain), first in red light ( $\lambda$  6907 Å.) then in blue light ( $\lambda$  4667 Å.) obtained from a monochromator. For each wavelength each optic axis in turn was centred by means of the interference figure, and the settings of the universal stage were adjusted to bring both optic axes into a vertical N.-S. plane. (This manner of orienting the plane of the optic axes simplifies the corrections required by the difference in refractive index of the glass hemispheres and the crystal plate.) The results, plotted on a stereographic net, show that the known dispersion of the optic axes,  $r > v$ , is accompanied by a dispersion of the acute bisectrix. The first plate, cut parallel to  $c(001)$ , gave  $2V$   $88.6^\circ$  in red light and  $2V$   $83.8^\circ$  in blue light; the second plate gave concordant values,  $88.5^\circ$  and  $84.0^\circ$  respectively. As to the difference in orientation of the two optical indicatrices, it is small but unmistakable (V. J. Hurst, observer).

In order to check the above results, plates cut parallel to  $b(010)$  were used to obtain the extinction angle, and three observers made independent measurements. In white light the extinction angle,<sup>1</sup> determined on the universal stage, is  $-3.1^\circ$  (Wm. S. MacKenzie, observer) and  $-3.2^\circ$  (J. R. Smith, observer). In monochromatic light the measurements were made on the stage of the microscope; as the plane of the plate was not rigorously parallel to  $b(010)$ , the extinction angles found were bound to be low:  $-2.0^\circ$  for blue light (Wratten filter 50,  $\lambda$  4500 Å.),  $-2.2^\circ$  for green (Wratten 74,  $\lambda$  5250 Å.), and  $-2.7^\circ$  for red (Wratten 70,  $\lambda$  7000 Å.) were obtained at one and the same point on the plate (J. D. H. Donnay, observer). Finally, in order to rule out the possibility that the crystal was triclinic, a plate cut normal to the  $c$ -axis was examined, to check that the  $b(010)$  face is a plane of optical symmetry. The plate showed traces of the  $m(110)$  and  $m(1\bar{1}0)$  faces; it was easy to check that the extinction direction bisects the angle between the  $m$  faces. In green light ( $\lambda$  5250 Å.) the readings for the extinction position and for the bisector of the angle  $mm$  differed by less than  $0.1^\circ$ ; for red light ( $\lambda$  7000 Å.) and blue light ( $\lambda$  4500 Å.) the differences were larger,  $0.4^\circ$  and  $0.3^\circ$  respectively, but the extinction position was much more difficult to ascertain (three observers, J. D. H. D., W. S. MacK., J. R. S.).

These results prove that staurolite is monoclinic, strongly pseudo-orthorhombic. They enable us to predict the existence of a new type of twin, 'by high order merohedry'.

<sup>1</sup> The negative sign given to the extinction angle means that the vibration direction lies between the  $+c$ -axis and the  $-a$ -axis. The crystal is oriented by making the larger  $r$  face (201).

*Twinning 'by high-order merohedry'.*

With  $\beta$  equal to  $90^\circ$  within the limits of error, staurolite comes close to being an example of the legendary 'high-order merohedry' (Friedel, 1926, p. 56), in which a monoclinic crystal would have an orthorhombic lattice. Twinning by pseudo-merohedry, with a vanishingly small obliquity (equal to zero within limits of error), can be called 'twinning by high-order merohedry'. Like twinning by merohedry it should give rise to penetration twins.

The following twin operations can be predicted: (a) reflection in (100), which, because of the monoclinic mirror, is equivalent to a  $180^\circ$  rotation about [001]; this twin law brings crystal I into coincidence, say, with crystal II; (b) reflection in (001), equivalent to a  $180^\circ$  rotation about [100]; this twin law brings crystal I into coincidence with crystal II'. If  $\beta \neq 90^\circ$ , X-ray photographs will show doubling of spots along the  $c^*$  row in case (a) and along the  $a^*$  row in case (b). In each of the two cases, the symmetry of the twin is  $2/m\ 2/m\ 2/m$ . If  $\beta = 90^\circ$  the two cases are indistinguishable, and the neighbouring twinned orientations II and II' merge into one. The twin law can then be expressed by any one of the four above operations, which function simultaneously as twin operations. The twin symmetry is again  $2/m\ 2/m\ 2/m$ , but neither the  $c^*$  row nor the  $a^*$  row should show any doubling of spots. The twin by high-order merohedry thus simulates an orthorhombic holohedral single crystal to perfection. Such twinning can conceivably occur on a very fine scale, which would further enhance the pseudo-symmetry shown by our precession photographs of 'single crystals'. Although such effects in X-ray diffraction may have vitiated the intensities,<sup>1</sup> so that the crystal structure of staurolite may have to be re-examined, they have little bearing on the interpretation of the previously known twins. The latter are simply superimposed on the new twin described in this section.

*Previously observed twins.*

Two types of twin are well known. The more common one consists of two interpenetrating crystals of simple prismatic habit (fig. 3) crossing each other at an angle of about  $60^\circ$  (fig. 4). The absence of  $r$  and  $r'$  faces on this twin is unusual. In the less common type of twin the two crystals have their  $c$ -axes at an angle of  $90^\circ$ ; one of the crystals is often larger than

<sup>1</sup> X-ray pictures taken at different temperatures would presumably show doubling of spots revealing the presence of twinning.

the other (fig. 9). We shall call these two types the 60°-cross (St. Andrew's cross) and the 90°-cross (Greek cross), respectively.

Diversity in the appearance of staurolite twins is attributable to five factors: (1) unequal development of forms (figs. 5, 6, and 8); (2) multiple

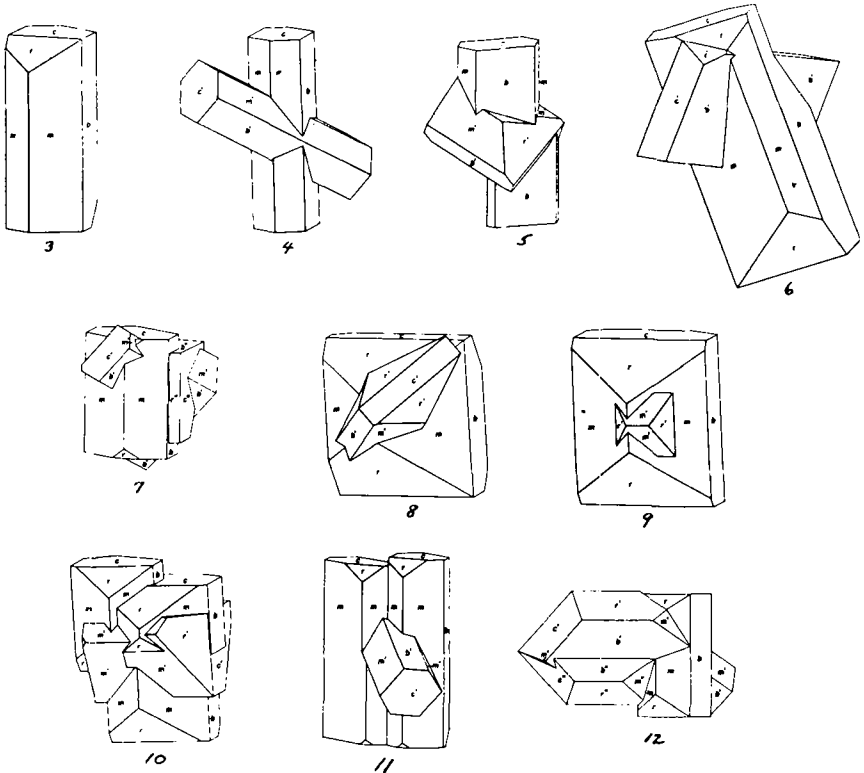

FIGS. 3-12. Portrait-drawings of staurolite specimens from Fannin County, Georgia: 3, Typical habit of staurolite crystal; 4, Typical 60°-cross; 5, 6, Malformed twins (60°-crosses); 7, Combined 60°-cross and 90°-cross; 8, Malformed 60°-cross; 9, Typical 90°-cross; 10, Parallel intergrowth and 90°-cross; 11, Parallel intergrowth and 60°-cross; 12, Trilling (repeated 60°-twin).

twinning (fig. 7); (3) repeated twinning (fig. 12); (4) combination of twinning with parallel intergrowth (figs. 10 and 11); (5) differences in the relative sizes of the twinned crystals.

The frequency of twinning and the ratio of the number of 60°-crosses to that of 90°-crosses vary greatly from place to place. In the various localities of Fannin County, Georgia, the proportion of twinned crystals

ranges from 10 to 75 %. The 60°-crosses greatly predominate, outnumbering the 90°-crosses nine to one.<sup>1</sup>

*Prediction of twin laws.*

Friedel (1904 ; 1926, p. 461) has shown how twin laws can be predicted—the possible twin operations being the operations of pseudo-symmetry of a multiple cell (or super-cell). He used one and the same cell to predict all the possible twin laws for both the 90°-cross and the 60°-cross. The

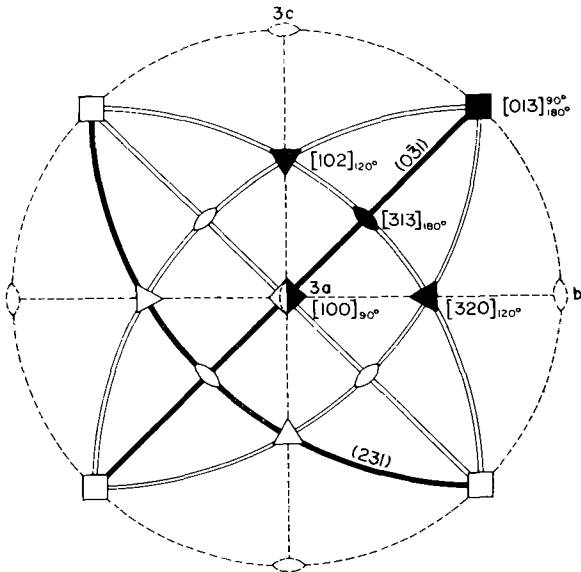

FIG. 13. Direct stereographic (cyclographic) projection of staurolite. Dashed lines: crystal pseudo-symmetry  $2/m \ 2/m \ 2/m$ . Solid lines: twin-lattice pseudo-symmetry  $4/m \ \bar{3} \ 2/m$ . Solid symbols: possible twin elements.

multiple cell is Mallard's pseudo-cube (Friedel, 1904, p. 293), which can be obtained from the structural cell by transformation  $013/0\bar{1}3/300$ . Friedel's treatment stands, with minor modifications to take the monoclinic symmetry into account (fig. 13). The pseudo-axes of fourfold symmetry

<sup>1</sup> Statistical data on staurolite specimens from Hackney's Farm, near Blue Ridge, Fannin County, Georgia; observations by Furcron (1949) in parentheses: Untwinned crystals 32.7 % (63.3 %); 60°-crosses 57.1 % (32.8 %); 90°-crosses 4.7 % (3.7 %); trillings of 60° twins 4.3 % (multiple twins 0.2 %); twin combinations and parallel growths 1.0 %; random intergrowths 0.2 %. Total number of crystals examined 1804 (1226).



are  $[013]$ ,  $[0\bar{1}3]$ ,  $[100]$ . The corresponding pseudo-mirrors are  $(031)$ ,  $(0\bar{3}1)$ ,  $(100)$ , respectively. The pseudo-axes of threefold symmetry are  $[102]$ ,  $[\bar{1}02]$ ,  $[320]$ ,  $[3\bar{2}0]$ . The pseudo-axes of twofold symmetry are:  $[313]$ ,  $[3\bar{1}3]$ ,  $[\bar{3}13]$ ,  $[\bar{3}\bar{1}3]$ ,  $[001]$ . The corresponding pseudo-mirrors are  $(231)$ ,  $(2\bar{3}1)$ ,  $(\bar{2}31)$ ,  $(\bar{2}\bar{3}1)$ ,  $(001)$ . We see that reflections in  $(100)$  and  $(001)$ , and rotations of  $180^\circ$  about  $[001]$  and  $[100]$  must now be added to the operations of pseudo-symmetry of the multiple cell. They define the twin by high-order merohedry described above. Among the other operations of pseudo-symmetry, the possible twin laws for the  $90^\circ$ -cross are: (1) rotation of  $\pm 90^\circ$  about  $[100]$ ; (2) rotation of  $180^\circ$  about  $[013]$  or  $[0\bar{1}3]$ ; (3) reflection in  $(031)$  or  $(0\bar{3}1)$ . The remaining operations of pseudo-symmetry are possible twin laws for the  $60^\circ$ -cross: (1) rotation of  $\pm 120^\circ$  about  $[102]$  or  $[\bar{1}02]$ ; (2) rotation of  $\pm 120^\circ$  about  $[320]$  or  $[3\bar{2}0]$ ; (3) rotation of  $180^\circ$  about  $[313]$ ,  $[3\bar{1}3]$ ,  $[\bar{3}13]$ , or  $[\bar{3}\bar{1}3]$ ; (4) reflection in  $(231)$ ,  $(2\bar{3}1)$ ,  $(\bar{2}31)$ , or  $(\bar{2}\bar{3}1)$ ; (5) rotation of  $\pm 90^\circ$  about  $[013]$ . In order to visualize the elements of pseudo-symmetry, it may be helpful to use multiple indices; for instance,  $[306]$  instead of  $[102]$ . The pseudo-cubic cell has multiplicity 18. Three nodes out of every 18 are restored by twinning; the twin index is 6.

It may be remarked that it is not necessary to call on the pseudo-cube in order to account for the  $90^\circ$ -cross. A pseudo-tetragonal multiple cell would suffice, either the triple cell obtained by transformation  $010/003/100$  or the sextuple cell given by  $013/0\bar{1}3/100$ . In either case the twin index is 3.

*Graphical determination of possible twin laws: the  $60^\circ$ -cross.*

Consider the polar stereographic projection (fig. 14) of a  $60^\circ$ -cross plotted from measurements. The coordinate axes of crystal I are  $xyz$ , those of crystal II are  $x'y'z'$ . Both systems are right-handed. Only four rotations are possible whereby crystal II can be brought to coincidence with crystal I (Friedel, 1920, p. 258; 1926, p. 246): (1)  $x'x$ ,  $y'y$ ,  $z'z$ ; (2)  $x'x$ ,  $y'\bar{y}$ ,  $z'\bar{z}$ ; (3)  $x'\bar{x}$ ,  $y'y$ ,  $z'\bar{z}$ ; (4)  $x'\bar{x}$ ,  $y'\bar{y}$ ,  $z'z$ . (In this notation  $x'x$  means that the  $x'$ -axis is brought on the positive  $x$ -axis, whereas  $x'\bar{x}$  means that the  $x'$ -axis is brought on the negative  $x$ -axis.)

1. The axis of the first rotation is the common line of intersection of the three planes ('perpendicular bisectors') which bisect the arcs  $xx'$ ,  $yy'$ ,  $zz'$ . This line, whose pole is **1**, nearly coincides with the zone axis  $[102]$  or with the normal to  $(101)$ . The angle of rotation is  $x'1x = y'1y = z'1z \approx 120^\circ$ .

2. The planes bisecting the arcs  $x'x$ ,  $y'\bar{y}$ ,  $z'\bar{z}$  intersect in a line whose

pole **2** lies near the pole of (130) and also near the pole of the zone axis [320]. The angle of rotation is  $x'2x = y'2y = z'2z \approx 120^\circ$ .

3. The planes bisecting the arcs  $x'\bar{x}$ ,  $y'y$ ,  $z'z$  intersect in a line whose pole **3** lies near the pole of ( $\bar{2}$ 31) and also near the pole of the zone axis [ $\bar{3}$ 13]. The angle of rotation is  $x'3\bar{x} = y'3y = z'3z \approx 180^\circ$ . Note that a

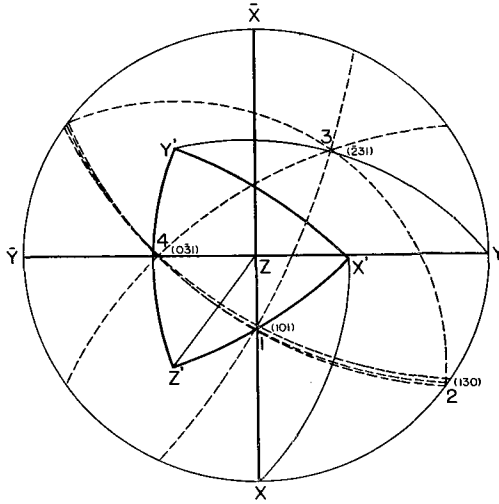

FIG. 14. Polar stereographic projection of staurolite, showing graphical determination of possible twin laws.

$180^\circ$ -rotation about the normal to ( $\bar{2}$ 31) is equivalent to a reflection in ( $\bar{2}$ 31) because the crystals are centrosymmetric.

4. The fourth rotation must be performed about the common line of intersection of the three planes that bisect the arcs  $x'\bar{x}$ ,  $y'\bar{y}$ ,  $z'z$ . This line, whose pole is **4**, nearly coincides with the zone axis  $[0\bar{1}3]$  or with the normal to (031). The angle of rotation is  $\bar{x}4x' = \bar{y}4y' = z4z' \approx 90^\circ$ .

According to Mallard's law, a row line can always be chosen as a twin axis and a net plane as a twin plane. The possible twin operations whereby one crystal may be brought to coincidence with the other are thus reduced to four rotations about row lines and one reflection in a net plane. They are, in self-explanatory notation:  $[102]_{120^\circ}$ ,  $[320]_{120^\circ}$ ,  $[313]_{180^\circ}$ ,  $[013]_{90^\circ}$ , and (231).

#### *The $90^\circ$ -cross.*

By using the same procedure as for the  $60^\circ$ -cross, one could show that the  $90^\circ$ -cross can be defined by only three twin operations, namely:

$[100]_{90^\circ}$ ,  $[013]_{180^\circ}$ , and  $(031)$ . Note that  $[100]_{+90^\circ}$  and  $[100]_{-90^\circ}$  lead to two neighbouring orientations, twinned with respect to each other by  $[100]_{180^\circ}$  if  $\beta \neq 90^\circ$ , but merging into one if  $\beta = 90^\circ$ . Note also that the two orientations obtained by  $[013]_{180^\circ}$  and  $[\bar{0}\bar{1}\bar{3}]_{180^\circ}$  are symmetrical to each other by reflection in  $(010)$  and so are the orientations obtained by reflections in  $(031)$  and  $(0\bar{3}1)$ .

The twin laws  $[013]_{180^\circ}$  and  $(0\bar{3}1)$  would be strictly equivalent if staurolite were orthorhombic. Indeed, the product of a twin reflection in  $(0\bar{3}1)$  by a crystal reflection in the orthorhombic mirror  $(100)$  is equivalent to a  $180^\circ$  rotation about  $[013]$ , the line of intersection of two reflection planes perpendicular to each other. Now that staurolite is known to be monoclinic, the two operations will lead to two neighbouring twinned orientations that, rigorously speaking, are distinct. Practically, however, it will not be possible to tell them apart. Either one, combined with twinning in  $(100)$ , will become equivalent to the other.

The possible twin operations determined graphically from the stereographic projections of measured staurolite twins are seen to be the same as the twin operations predicted on the basis of pseudo-symmetry.

*Twin laws indicated by morphology.*

Previous workers have always assumed that there can be only one twin law for each type of cross, and they have endeavoured to ascertain it. For the  $60^\circ$ -cross, for instance, reflection in  $(231)$  had long—and uncritically—been accepted as the twin law. Friedel (1922) tried to refine the goniometric data in an effort to distinguish between the five possible definitions. He measured the angle  $b_I b_{II}$  between  $b(010)$  of crystal I and  $b(010)$  of crystal II. The average of 46 measurements gave him the value of  $120^\circ 2'$ , with maximum deviations of  $\pm 52'$  (in one case  $+71'$ ) and  $-50'$ . By comparison with the predicted values for  $b_I b_{II}$  (recalculated by us),<sup>1</sup> he concluded that rotation of  $120^\circ$  about  $[102]$  afforded the best definition of the twin. The spread of his measurements ( $102'$ ) exceeded the largest difference ( $72'$ ) between the predicted values. We can only confirm Friedel if we adopt his line of approach. Eight of the best  $60^\circ$ -crosses, selected from the 1804 specimens from

<sup>1</sup> Predicted angle  $b_I b_{II}$  for each of the twin laws, based on  $a:b:c = 0.473_1:1:0.341_0$

60°-cross	{ twin law	$[102]_{120^\circ}$	$[320]_{120^\circ}$	$[313]_{180^\circ}$	$(231)$	$[013]_{90^\circ}$
	{ predicted $b_I b_{II}$	$120^\circ 0'$	$119^\circ 49'$	$120^\circ 30'$	$119^\circ 30'$	$119^\circ 18'$
90°-cross	{ twin law	$[100]_{90^\circ}$	$[013]_{180^\circ}$ or $(031)$			
	{ predicted $b_I b_{II}$	$90^\circ 0'$	$91^\circ 14'$			

Fannin County, gave us  $b_I b_{II} = 119^\circ 59'$ , with maximum deviations of  $+55'$  and  $-50'$ . Five measurements of  $b_I b_{II}$  in  $90^\circ$ -crosses gave us an average value of  $89^\circ 55'$  (range  $89^\circ 40'$  to  $90^\circ 6'$ ), which, compared with predicted values, tends to confirm Friedel's suspicion that  $[100]_{90^\circ}$  would be the best twin law.

Averaging the values of  $b_I b_{II}$ , however, can have significance only if, as Friedel supposed, the large range of measurements is wholly due to macroscopic crystal deformation. Our X-ray results will show that this is not the case. The occurrence of several twin laws can also account for the spread of the measurements of  $b_I b_{II}$ .

### *Space group and cell dimensions.*

Because the space group indicated by the morphology differed from *Ccmm*, previously reported in the literature,<sup>1</sup> the study of systematic extinctions was repeated with Buerger's precession method (1944). All the observed reflections obey the criterion ' $(h+k)$  even'. No other presence criterion is found for any set of reflections. The  $(0kl)$  reflections with  $l$  odd are very weak, but definitely visible on several photographs; for instance: 021, 041, 061, 081, 0.10.1, 0.12.1, 023, 043, 065, 0.12.5. The diffraction aspect is thus *C\*\*\**, while *Cc\*\** is a pronounced pseudo-aspect. The crystal structure proposed by Náray-Szabó (1929) will have to be revised: the  $c$  glide plane parallel to (100) must be eliminated and the space group must become *C2/m*, to agree with the results of the optical study; the intensities must be checked to guard against possible misleading effects due to twinning, on which Buerger (1954) has recently commented. The fact that the  $\beta$  angle, if different from  $90^\circ$ , is close to it, supports the known structural result that (100) of kyanite is parallel to (010) of staurolite in the epitaxial overgrowth of one mineral on the other; indeed, the  $\alpha$  angle of kyanite, which would correspond to the  $\beta$  angle of staurolite, is reported as  $90^\circ 5'$  in the literature.

We determined the cell dimensions of seven different specimens, in the hope of finding some relationship (through the obliquity) between twin law and axial ratios. (As we shall see presently, this hope did not materialize.) The results are listed in table I, together with data of previous workers. They show appreciable ranges of variation (for all

<sup>1</sup> Space group *Pmab* given by Gottfried (1927) was due to erroneous indexing (Strukturbericht, 1931, vol. 1, p. 453).

Lusakite was described (Skerl, Bannister, and Groves, 1934) as a cobalt-bearing staurolite, with space group *Ccmm*. These authors point out that the staurolite structure is not as simple as that proposed by Náray-Szabó (1929).

TABLE I. Variations of cell dimensions and axial ratios in staurolite specimens. Cell dimensions of first seven specimens given to ... 0.3 %. Angle  $\beta$  equal to 90° within limits of error,  $\pm 3'$ .

Locality.	<i>a</i> (Å.).	<i>b</i> (Å.).	<i>c</i> (Å.).	<i>a:b:c</i> .	Remarks.
Hackney's Farm, Fannin Co., Georgia	7.86	16.56	5.67	0.471 <sub>3</sub> :1:0.338 <sub>8</sub>	Typical specimen from Hackney's Farm.
	7.94 <sub>9</sub>	16.64 <sub>4</sub>	5.68 <sub>2</sub>	0.477 <sub>6</sub> :1:0.341 <sub>4</sub>	60°-cross, twin law [313] <sub>hac</sub> , plate No. 1.
	7.86 <sub>8</sub>	16.61 <sub>0</sub>	5.67 <sub>6</sub>	0.473 <sub>7</sub> :1:0.341 <sub>9</sub>	" " " " plate No. 2.
	?	16.81 <sub>6</sub>	5.71 <sub>0</sub>	? : 1:0.339 <sub>6</sub>	90°-cross, twin law [100] <sub>hac</sub> .
	?	16.50	5.61 <sub>7</sub>	? : 1:0.340 <sub>4</sub>	" " twin law [013] <sub>hac</sub> .
Ducktown, Tennessee	7.88	16.64	5.67	0.473 <sub>8</sub> :1:0.340 <sub>7</sub>	From powder pattern taken on Philips diffractometer.
Namib, Africa	7.87	16.72	5.68	0.470 <sub>7</sub> :1:0.339 <sub>9</sub>	U.S. National Museum No. 8642.
?	7.86	16.55	5.62	0.474 <sub>6</sub> :1:0.339 <sub>6</sub>	(Gottfried, * 1927. (Å. from kX.)
Monte Campione	7.83	16.62	5.65	0.470 <sub>8</sub> :1:0.340 <sub>0</sub>	Cardoso, * 1927. (Å. from kX.)
St. Gotthard	7.84	16.55	5.64	0.473 <sub>4</sub> :1:0.340 <sub>8</sub>	Náray-Szabó, 1929. (Å. from kX.)
N. Rhodesia	7.88	16.65	5.66	0.473 <sub>4</sub> :1:0.340 <sub>0</sub>	Lusakite, Skerl <i>et al.</i> , 1934. (Å. from kX.)
Hackney's Farm	--	--	--	0.472 <sub>3</sub> :1:0.340 <sub>2</sub>	Average ratios based on 15 crystals.
?	--	--	--	0.473 <sub>4</sub> :1:0.341 <sub>0</sub>	Des Cloizeaux's values ( <i>c</i> /2).
?	--	--	--	0.473 <sub>4</sub> :1:0.341 <sub>0</sub>	Hörner's values ( <i>c</i> /2).

\* Note misprint in Strukturbericht, vol. 1, p. 453: instead of  $c = 6.61$ , read  $c = 5.61$ (kX). Also on p. 487: 0.4726 and 0.4708 are interchanged.

localities): 1.5 % for  $a$  and  $c$ ; 1.9 % for  $b$ . The single locality of Hackney's Farm shows a larger range of values than all other localities put together: for  $a$ , 1.1 % as compared with 0.6 %; for  $b$ , 1.9 % against 1.0 %; and for  $c$ , 1.5 % against 1.0 %. Each of the axial ratios has a range of variation of about 1 %. Such variations are to be expected in view of the variable chemical composition of staurolite.

*Actual twin laws found by X-rays.*

As was pointed out by Buerger (1944), the precession instrument is particularly well suited to the study of twinning. A plane-parallel plate, about 0.5 mm. thick, is cut from the twin, by the standard techniques for grinding oriented sections of crystals. The plane of grinding is chosen, by visual inspection, normal to the suspected twin element, either ( $a$ ) twin plane, or ( $b$ ) twin axis.

( $a$ ) In the case of a suspected twin plane ( $hkl$ ), the plate is mounted and adjusted on the precession instrument in such a way that ( $hkl$ ) contains (is parallel with) the X-ray beam. Both individuals of the twin may be diffracting simultaneously, or each one can be made to diffract in turn by translating the plate and taking a double exposure. If ( $hkl$ ) is a twin plane, whether or not the beam is normal to a reciprocal-lattice *net*, the reciprocal-lattice rows  $[hkl]_{\text{I}}^*$  and  $[hkl]_{\text{II}}^*$  of crystals I and II coincide along the dial axis of the instrument and will appear as a single row of diffraction spots on the photograph.

( $b$ ) In the case of a suspected twin axis  $[uvw]$ , the plate is mounted and adjusted with  $[uvw]$  along (parallel with) the X-ray beam. If  $[uvw]$  is a twin axis the reciprocal-lattice nets  $(uvw)_{\text{I}}^*$  and  $(uvw)_{\text{II}}^*$  of crystals I and II lie in a common plane parallel to the film. The photograph will show the two nets rotated with respect to each other, about the trace of the twin axis, through the angle of the twin rotation ( $90^\circ$ ,  $120^\circ$ ,  $180^\circ$ , as the case may be).

Another method of identifying a twin axis, developed during the present study, has been described elsewhere (Donnay, Donnay, and Hurst, 1955). Even if the twin axis  $[uvw]$  is only roughly adjusted along the direct beam, the nets  $(uvw)_{\text{I}}^*$  and  $(uvw)_{\text{II}}^*$  will lie in the same plane and will produce, on an orientation photograph, a *single* 'limiting circle'—the 'circle' due to the sharp cut-offs of white-radiation streaks, which is used in the adjustment procedure. If  $(uvw)_{\text{I}}^*$  and  $(uvw)_{\text{II}}^*$  produce two limiting circles, one of them, say  $(uvw)_{\text{I}}^*$ , can be centred by proper adjustment, which brings  $[uvw]_{\text{I}}^*$  along the X-ray beam. The

eccentricity of the other circle gives the angle  $[uvw]_{\text{I}}^* : [uvw]_{\text{II}}^*$ , whence the proposed name of 'precession goniometry'.

Three 90°-crosses from Hackney's Farm were studied. Plates were ground normal to [100]. In two cases the twin law was established as  $[100]_{90^\circ}$ . On a zero level photograph of such a twin (shown in pls. V and VI A), the  $b_{\text{I}}^*$ - and  $c_{\text{II}}^*$ -axes coincide. In the third case, the appearance of two limiting circles indicated that the twin law could not be  $[100]_{90^\circ}$ ; it could only be  $[013]_{180^\circ}$ . This was confirmed by adjusting the plate with [013] along the beam and taking another picture, on which only one limiting circle was visible (pls. V and VI B).

The 60°-crosses are more complicated, as five possible twin laws must be distinguished. Plates were cut normal to [102], the suspected twin axis. In one case the twin law  $[102]_{120^\circ}$  was, indeed, established (pls. V and VI c). In two other cases two limiting circles appeared, from which the angle between the two corresponding direct rows could be determined by precession goniometry. If the cell dimensions have been determined for the particular specimen under investigation, such an angle can be calculated for every possible twin law. A comparison between measured and calculated angles will then disclose the actual twin law, provided the calculated angles are known with sufficient accuracy to make the comparison a significant one. Our cell dimensions are known to  $\pm 0.3\%$ ; as a result our calculated angles may vary by as much as  $\pm 33'$ , but the ranges of the various angles need not necessarily overlap and the method may still be applicable (for table of calculated angles of staurolite twins, see Donnay, Donnay, and Hurst, 1955). If the cell dimensions have not been determined for the specimen in question, the method cannot be trusted because of the variability of the axial ratios. For instance, the calculated angle  $[10\bar{2}]_{\text{I}} : [\bar{1}02]_{\text{II}}$  is found to be  $1^\circ 55'$  (range  $1^\circ 22'$  to  $2^\circ 29'$ ) or  $0^\circ 59'$  (range  $0^\circ 26'$  to  $1^\circ 32'$ ), according as the cell dimensions (table I) of plate No. 1 or of plate No. 2 are used. We have checked each of the possible twin laws by taking an orientation picture with the X-ray beam along the twin axis or contained in the twin plane. The two twins mentioned above turned out to obey the twin law  $[313]_{180^\circ}$  (pls. V and VI D).

The reorientations necessary for testing the different twin laws on the same plate are done on a two-circle goniometer. All available reflections are used, including those of the cleavage planes  $b$  and  $m$ , which can still be observed on the plate after grinding. The desired positions of the faces in the new orientation are first plotted on a stereographic projection of the twin. The plate, mounted in wax, can then be pushed into

the position where each face reflects at the correct  $\phi$  and  $\rho$  settings read off the projection.

A plate ground normal to a certain direct-lattice row, suspected to be a twin axis, will not be normal to the beam any more after it has been reoriented to test another twin possibility. Even in the worst case of a horizontal plate, nearly parallel to the X-ray beam, a usable picture was obtained. If, however, the specimen is large, it is better to saw it into halves and to grind two plates: one plate normal to [102] for a first photograph, from which a prediction can be made as to the probable twin element, and a second plate normal to this expected twin element.

The obliquity of the twin (Friedel, 1926, p. 249) is a function of the axial ratios. For example, the obliquity of the twin  $[102]_{120^\circ}$  varies from  $0^\circ 41'$  to  $1^\circ 8'$  when  $a/b$  ranges from  $0.474_6$  to  $0.470_3$  and  $c/b$  from  $0.341_4$  to  $0.338_5$ . For the same ranges of the axial ratios, we calculated the following obliquities: for  $[320]_{120^\circ}$ ,  $0^\circ 10'$  to  $0^\circ 24'$ ; and for  $[013]_{90^\circ}$ ,  $[013]_{180^\circ}$ , or  $(031)$ ,  $0^\circ 54'$  to  $1^\circ 22'$ . For plate No. 1 and plate No. 2 (table I), the obliquities are  $0^\circ 58'$  and  $1^\circ 7'$ , respectively (ranges not calculated), for both twin laws  $[313]_{180^\circ}$  and  $(231)$ . For  $[100]_{90^\circ}$  the obliquity, defined as the angle between  $[100]$  and the normal to  $(100)$ , is equal to zero if  $\beta = 90^\circ$ .

We can observe that the obliquities are all small (about  $1^\circ$  or less), on which ground all seven twin laws could be expected to occur; but we have not been able to prove that the obliquity determines the twin law. Note that all the twin laws actually observed are twin axes, which explains why the twins are penetrations. It is known (Friedel, 1904) that if the twin law were reflection in  $(231)$ , the composition surface would be expected to be planar and parallel to  $(231)$ ; such is not the case.

#### *The unproved twin law of Dana.*

A staurolite twin with  $(230)$  or  $(\bar{1}30)$  as twin plane has been reported by E. S. Dana (1876). It is represented by a single specimen collected in Fannin County, Georgia. The measured angle between the twinned  $b$  faces was reported as  $70^\circ 30'$ . Twinning in  $(230)$  would require this angle to be  $70^\circ 45\frac{1}{2}'$ ; twinning in  $(\bar{1}30)$  would make it  $70^\circ 18'$  (Dana, 1892, p. 560). Friedel (1926, p. 462) has pointed out that the proposed twin planes,  $(230)$  and  $(\bar{1}30)$ , are respectively octahedral and leucitohedral faces of the pseudo-cube and that the twin might be described by a  $180^\circ$  rotation about  $[320]$  or  $[3\bar{2}0]$ , which are two of the threefold axes of the pseudo-cube. However, the existence of a new twin can be established only by the accuracy of the measurements or by the frequency of



occurrence. We have not encountered any example of this twin, although we examined several thousand specimens from Fannin County. It is therefore yet to be demonstrated that what Dana reported as a twin is not a random intergrowth.

### Conclusions.

The old assumption that each type of staurolite cross obeys one twin law only is unjustified. We have observed four of the predicted seven laws. Should these be the only ones to be expected? There is no obvious reason why they should. The other twin axes may well occur, especially  $[320]_{120^\circ}$ , which has the smallest obliquity. The small number of twins on which we have determined the twin law permits no generalization.

Having established that for the  $90^\circ$ -cross the two possible twin laws exist and that for the  $60^\circ$ -cross more than one twin law is obeyed, we do not feel that it would be of any particular interest to search for the remaining ones.

*Acknowledgements.* - We are greatly indebted to Dr. W. S. MacKenzie and Dr. J. R. Smith for discussing and checking our optical results. Thanks are also due to Dr. Elizabeth A. Wood, Dr. H. Eugster, and Mr. D. Appleman for constructive criticism of the manuscript.

### APPENDIX.

#### *Morphological determination of the space group.*

CONSIDER the gnomonic projection (fig. 1). The following facts are observed: (1) only one  $(hkl)$  form,  $s$ , is known; (2) only one  $(hk0)$  form,  $m$ , is known; (3) the zone of the  $(0kl)s$  is a *simple zone* (Donnay, 1938), with  $q$  more frequent than  $l$ ; (4) the zone of the  $(h0l)s$  is a *simple zone*, with  $r$  dominant; (5) the three pinacoids are observed, with  $b$  about as frequent as  $m$ ,  $c$  more frequent than  $r$ ,  $a$  uncommon.

The choice of the unit face rests on the following considerations. Face  $s$  must be indexed (111), unless the lattice is body-centred, in which case the sum of the indices should be even and  $s$  must be (112). Neither  $s(121)$  nor  $s(211)$  would be compatible with the presence of  $q$ ,  $r$ , and  $m$  as dominant forms in the axial zones, for the latter must be indexed (011), (101), and (110), respectively, in order to obey the lattice criterion 'sum even'.

First let  $s$  be (111). If the lattice were  $F$ , the dominant faces in the axial zones would be at unit distances from the  $c$  pinacoid; this is ruled out by  $q$  and  $r$ . The  $A$  and  $B$  lattices are likewise ruled out by  $q$  and  $r$ .

The  $C$  lattice is possible with the dominant faces  $q(021)$  and  $r(201)$  correctly shifted 'away from the centred pinacoid' (Donnay, 1939). In this case  $c$  must be (001), not (002), as its reciprocal-lattice vector 0.177 must be smaller than that of  $q$ , which is equal to 0.214 (fig. 2). Because  $m$  is more frequent than  $a(200)$  and as frequent as  $b(020)$ , it must be indexed  $m(110)$ , not (220). The reciprocal-lattice vectors are 0.140 for  $m(110)$ , 0.120 for  $b(020)$ , and 0.253 for  $a(200)$ . These two conclusions uniquely determine the morphological aspect as  $C^{***}$ , compatible with five possibilities:  $Cmmm$ ,  $C222$ ,  $C2mm$ ,  $Cm2m$ , and  $Cmm2$ . (If the symmetry were

monoclinic, the aspect would be  $C^*$ , with the possible space groups  $C2/m$ ,  $C2$ , and  $Cm$ .)

The  $P$  lattice is also possible, with aspect  $Pban$  or  $Pba^*$ . If the zone of the  $(hk0)s$  were a *simple zone*, one would expect (120) to have been observed, for its reciprocal-lattice vector  $L^*(120) = 0.173$  is smaller than that of  $c(001)$ . If the zone is made a *double zone* (Donnay, 1938), the next face would be (130), with  $L^*(130) = 0.219$ ; it has not been reported, which is anomalous, in view of the occurrence of  $r$  with  $L^*(201) = 0.309$ . The double zone, however, is less anomalous than the simple zone. This interpretation uniquely defines  $Pban$ , a space group that would require the point-group symmetry to be orthorhombic holohedral.

Now let  $s$  be (112), with an  $I$  lattice. The reciprocal vector  $c^*$  must be halved, as compared with its value on fig. 2. All forms must have their third index doubled. The  $I$  lattice requires that in each axial zone the unit face shall be dominant, with indices coprime, and that the zone shall be of the double-zone type. Since the  $(0kl)s$  and  $(h0l)s$  both form simple zones, glide planes must be inferred. The zone of the  $(hk0)s$  is not affected by any glide plane; if it were,  $m$  would be (220) and its importance ( $m > a$ ) would not be properly expressed. The only possible aspect, with an  $I$  lattice, is  $Iba^*$ .

In order to decide between  $C^{***}$ ,  $Pban$ , and  $Iba^*$ , we must be guided by the general forms  $(hkl)$ , for all other forms obey the same conditions in all three aspects. The latter can best be compared if the cell of  $Iba^*$  (with  $c$  doubled) is also used for  $C^{***}$  and  $Pban$ . The conditions then become: for  $Pban$ ,  $l$  even; for  $C^{***}$ ,  $(h+k)$  even and  $l$  even; for  $Iba^*$ ,  $(h+k+l)$  even, which can be fulfilled in two ways: either  $(h+k)$  even with  $l$  even, or  $(h+k)$  odd with  $l$  odd. It is clear that more forms could be expected with  $Pban$  or with  $Iba^*$  than with  $C^{***}$ . The observed fact is that only one  $(hkl)$  form is known. It follows that  $C^{***}$ , which imposes the most restrictive conditions, is the best choice on morphological evidence.

#### References.

- BISWAS (S. L.), 1928. *Quart. Journ. Geol., Min. Met. Soc. India*, vol. 1, p. 151 [M.A. 5-37].
- BUERGER (M. J.), 1944. *The photography of the reciprocal lattice*. ASXRED Monograph No. 1 [M.A. 10-10].
- 1954. *Anais Acad. Brasil. Ciências*, vol. 26, p. 111.
- CARDOSO (G. M.), 1928. *Zeits. Krist.*, vol. 66, p. 485 [M.A. 3-529].
- DANA (E. S.), 1876. *Amer. Journ. Sci.*, ser. 3, vol. 11, p. 384.
- 1892. *System of Mineralogy*, 6th edn, New York.
- DONNAY (GABRIELLE) and DONNAY (J. D. H.), 1954. *Acta Cryst.*, vol. 7, p. 619.
- — and HURST (V. J.), 1955. *Ibid.*, vol. 8, p. 507.
- DONNAY (J. D. H.), 1938. *Ann. (Bull.) Soc. géol. Belg.*, vol. 61, p. B260 [M.A. 7-242].
- 1939. *Amer. Min.*, vol. 24, p. 184.
- 1947. *Bull. Soc. franç. Min.*, vol. 69, p. 151 (1946) [M.A. 10-466].
- and HARKER (D.), 1937. *Amer. Min.*, vol. 22, p. 446 [M.A. 7-241].<sup>1</sup>
- EVANS (R. C.), 1946. *An introduction to crystal chemistry*, Cambridge.
- FRIEDEL (G.), 1904. *Étude sur les groupements cristallins*. *Bull. Soc. Ind. Min.* (4), vols. 3-4. Reprinted in book form, Saint-Étienne, 1904.

<sup>1</sup> Note misprint in M.A. 7-241, last line: *instead of hexagonal mode, read hexahedral mode.*

- FRIEDEL (G.), 1920. Bull. Soc. franç. Min., vol. 43, p. 246 [M.A. 2-368].  
 — 1922. Ibid., vol. 45, p. 8 [M.A. 2-144].  
 — 1926. Leçons de cristallographie, Paris. (See pp. 245-252 and 421-493.)  
 FURCROU (A. S.), 1949. The Earth Science Digest, vol. 3, No. 7, p. 7.  
 GOLDSCHMIDT (V.), 1922. Atlas der Kristallformen, vol. 8, Heidelberg [M.A. 2-289].  
 GOTTFRIED (C.), 1927. Zeits. Krist., vol. 66, p. 103 [M.A. 3-434].  
 NÁRAY-SZABÓ, 1929. Ibid., vol. 71, p. 103 [M.A. 4-160].  
 SKERL (A. C.), BANNISTER (F. A.), and GROVES (A. W.), 1934. Min. Mag., vol. 23, pp. 598, 633.  
 WEISS (K.), 1901. Zeits. Ferdinandeum, Innsbrück, ser. 3, vol. 45, p. 129.

## EXPLANATION OF PLATE V.

Precession photographs of four different staurolite twins, plate ground normal to twin axis, X-ray beam along the twin axis. Mo- $K\alpha$  radiation. Precession angle  $30^\circ$  in A, B, C;  $25^\circ$  in D. Reciprocal-lattice nets shown in solid line for crystal I, in dashed line for crystal II.

- A.  $90^\circ$ -cross; twin law  $[100]_{90^\circ}$ .  
 B.  $90^\circ$ -cross; twin law  $[013]_{180^\circ}$ .  
 C.  $60^\circ$ -cross; twin law  $[102]_{120^\circ}$ .  
 D.  $60^\circ$ -cross; twin law  $[313]_{180^\circ}$ . Reciprocal-lattice nets coincide; only one crystal indexed.

## EXPLANATION OF PLATE VI.

Same photographs as on Plate V before reciprocal-lattice nets were drawn in.

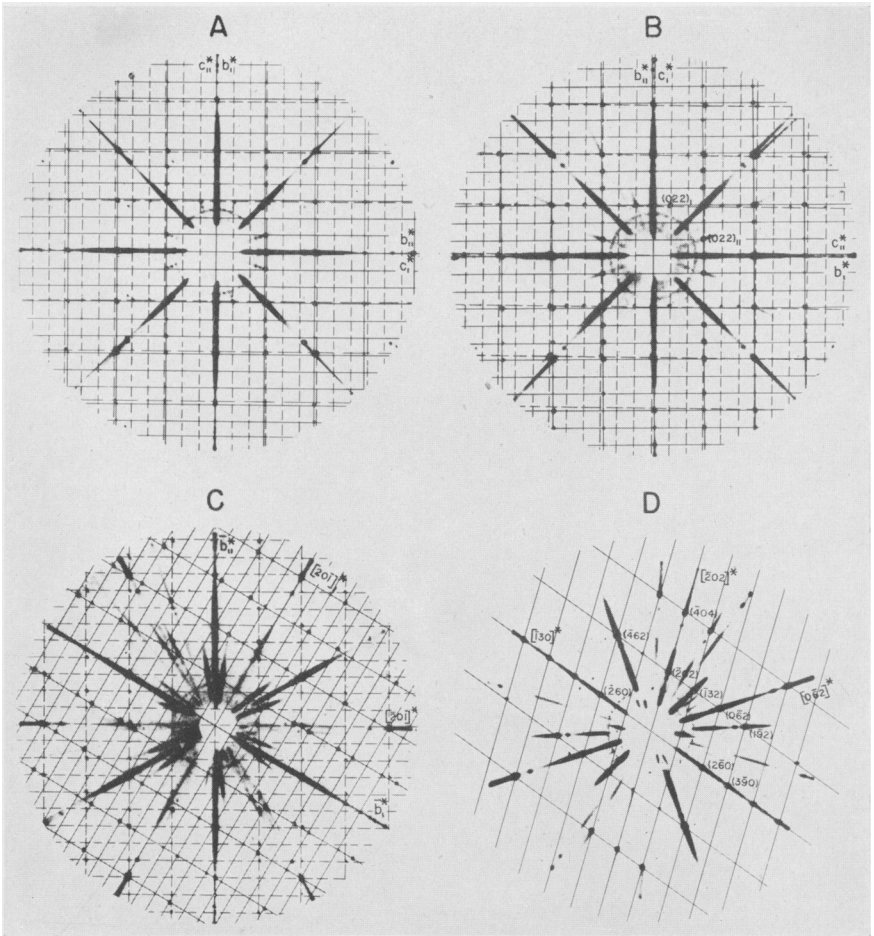

HURST, DONNAY, AND DONNAY: STAUROLITE TWINNING

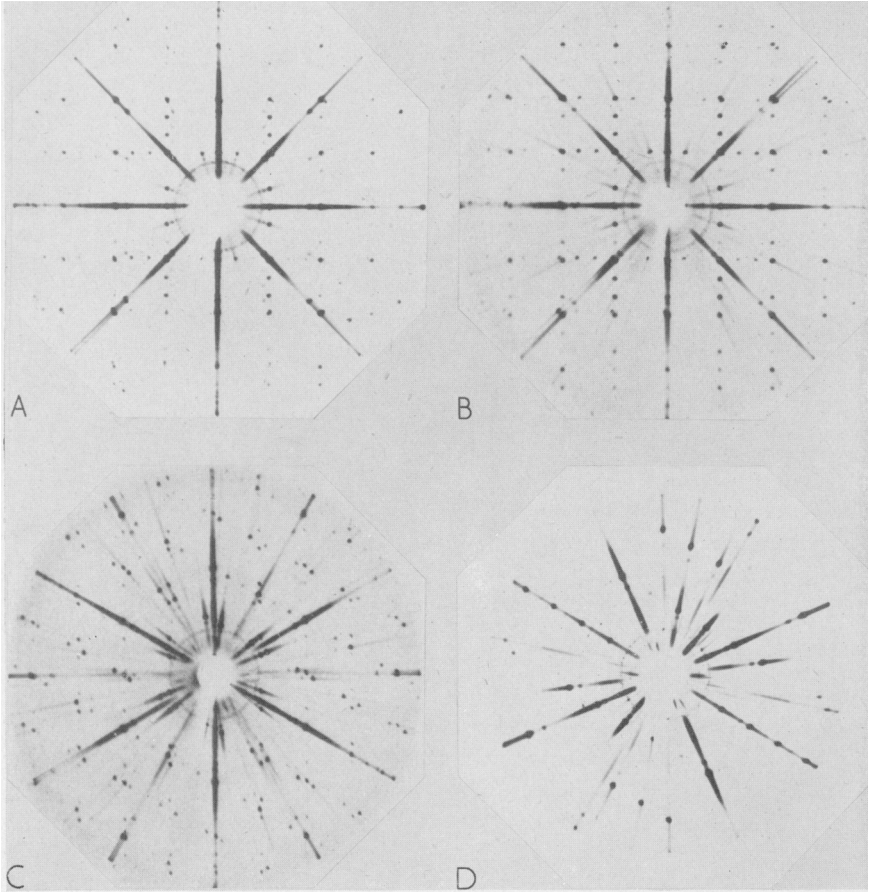

HURST, DONNAY, AND DONNAY: STAUROLITE TWINNING