

# A PRELIMINARY STRUCTURE FOR PUCHERITE, $\text{BiVO}_4$

M. M. QURASHI<sup>1</sup> AND W. H. BARNES

*Division of Physics, National Research Council, Ottawa, Canada.*

## ABSTRACT

The unit cell of pucherite,  $\text{BiVO}_4$ , is orthorhombic with  $a=5.33_2$  A,  $b=5.06_0$  A,  $c=12.02$  A and  $Z=4$ . The space group is  $Pnca$ . A preliminary structure is described with Bi and V at  $\frac{1}{4}0z$ ;  $\frac{3}{4}0\bar{z}$ ;  $\frac{1}{4}, \frac{1}{2}, \frac{1}{2}+z$ ;  $\frac{3}{4}, \frac{1}{2}, \frac{1}{2}-z$ , ( $z_{\text{Bi}} \simeq 0.108$ ;  $z_{\text{V}} \simeq 0.39_2$ ). Eight O are in  $000$ ;  $\frac{1}{2}00$ ;  $0\frac{1}{2}\frac{1}{2}$ ;  $\frac{1}{2}\frac{1}{2}\frac{1}{2}$  and  $00\frac{1}{2}$ ;  $\frac{1}{2}0\frac{1}{2}$ ;  $0\frac{1}{2}0$ ;  $\frac{1}{2}\frac{1}{2}0$ . The remaining 8 O are in general positions with  $x \simeq -\frac{1}{3}_0$ ,  $y \simeq \frac{1}{4} + \frac{1}{3}_0$ ,  $z \simeq \frac{1}{4} - \frac{1}{3}_0$ .

## INTRODUCTION

Pucherite,  $\text{BiVO}_4$ , is better crystallized, and has been characterized more satisfactorily (Dana, 1947), than many of the vanadium minerals (Barnes & Qurashi, 1952). Single crystals, however, are very small and curved faces are common.

In a short note, de Jong and de Lange (1936) report axial lengths, from x-ray rotation photographs of material from Schneeberg, Saxony, as  $a=5.38$  A,  $b=5.04$  A,  $c=11.98$  A, with an estimated accuracy of  $\pm 0.03$  A. The wave-length of the Fe radiation employed is not given but presumably A should be replaced by kX units. They assumed the cell to be orthorhombic in agreement with the morphological data, and calculated a value of 6.57 for the specific gravity if there are 4 formula units per cell. They point out that this differs appreciably from 6.25, the value given in the literature. Owing to lack of suitable material, de Jong and de Lange were unable to determine the specific gravity of their material, nor were they able to fix the space group.

Through the courtesy of Professor Clifford Frondel a specimen of pucherite, also from the type locality, Schneeberg, (Harvard No. 101703), was obtained for a structure determination as part of a general programme on the vanadium minerals.

## UNIT CELL AND SPACE GROUP

Throughout this investigation, a Buerger precession instrument was employed with Mo  $K\alpha$  radiation ( $\lambda=0.7107$  A).

The unit cell was found to be orthorhombic, in agreement with the assumption of de Jong and de Lange (1936), with  $a=5.33_2 \pm .005$  A,  $b=5.06_0 \pm .005$  A,  $c=12.02 \pm .01$  A. The length of the  $a$  axis is about 1% smaller than that found by de Jong and de Lange but the lengths of the other two axes are almost the same. If the specific gravity is taken as 6.25 the number of formula units per cell ( $Z$ ) is 3.77 which not only shows that there are 4  $\text{BiVO}_4$  per unit cell but also confirms doubts regarding the

<sup>1</sup> National Research Laboratories Postdoctorate Fellow.

validity of the experimental value for the specific gravity. Single crystals were so small that an accurate redetermination of the specific gravity on suitable material was not possible even by the flotation method. The calculated density is 6.63 g/ml. It is possible, of course, that some degree of substitution of Bi or V by other atoms might account for the discrepancy between the calculated values and 6.25.

Comparison of upper level with zero level precession films reveals the presence of an  $n$  glide perpendicular to  $a$ , a  $c$  glide perpendicular to  $b$ , and an  $a$  glide perpendicular to  $c$ . The space group is thus uniquely established as  $Pnca$  ( $D_{2h}^{14}$ ), retaining the same orientation as that used by de Jong and de Lange (1936).

#### PRELIMINARY STRUCTURE

With  $Z=4$ , there are 4 Bi, 4 V, and 16 O to locate in the unit cell.

In space group  $Pnca$  there are three possible 4-fold positions and one general 8-fold position. The metal ions, therefore, must be in the 4-fold positions.

In addition to the characteristic space group extinctions,  $(0kl)$  if  $k+l$  odd,  $(h0l)$  if  $l$  odd,  $(hk0)$  if  $h$  odd, the general  $(hkl)$  reflections are very weak (only about 0.01 the intensity of the strong ones) when  $(k+l)$  is odd. Thus most of the atoms, including the Bi and V, must be in the special 4-fold positions.

Intensities were estimated visually from multiple film exposures and a preliminary inspection suggested that the heaviest atoms, Bi, were in special positions  $(c)$ ,  $\frac{1}{4} 0 z$ ;  $\frac{3}{4} 0 \bar{z}$ ;  $\frac{1}{4}, \frac{1}{2}, \frac{1}{2} + z$ ;  $\frac{3}{4}, \frac{1}{2}, \frac{1}{2} - z$ , with  $z \sim \frac{1}{8}$ .

Patterson projections on  $h0l$  and  $0kl$  verified the Bi positions and gave  $z = 0.10_8$ . The four V atoms were found to occupy the same type of positions but with  $z \sim 0.39_2$ . Eight O atoms were located in special positions  $(a)$ ,  $000$ ;  $\frac{1}{2} 00$ ;  $0 \frac{1}{2} \frac{1}{2}$ ;  $\frac{1}{2} \frac{1}{2} \frac{1}{2}$ , and  $(b)$   $00 \frac{1}{2}$ ;  $\frac{1}{2} 0 \frac{1}{2}$ ;  $0 \frac{1}{2} 0$ ;  $\frac{1}{2} \frac{1}{2} 0$ . The remaining eight O atoms are in the general positions  $(d)$ ,  $x, y, z$ ;  $\frac{1}{2} + x, \frac{1}{2} - y, \frac{1}{2} - z$ ;  $\bar{x}, \frac{1}{2} + y, \frac{1}{2} - z$ ;  $\frac{1}{2} - x, \bar{y}, z$  (and these with changed signs), where  $x \sim -\frac{1}{30}$ ,  $y \sim \frac{1}{4} + \frac{1}{30}$ ,  $z \sim \frac{1}{4} - \frac{1}{30}$ .

The preliminary structure so obtained is shown projected along the  $c$  and  $b$  axes in Fig. 1a. It gives very good agreement with the observed  $(hkl)$  intensities, the weak ones from planes with  $k+l \neq 2n$  being due solely to the eight oxygen atoms in the set of general positions. Furthermore, the perfect  $\{001\}$  cleavage of pucherite is accounted for by the weak Van der Waals' bonds between oxygens across the planes at  $z = \pm \frac{1}{4}$ .

It is hoped to refine the structure by Fourier projections, and to obtain the oxygen parameters more accurately from an independent analysis of the intensities of the  $(hkl)$  reflections with  $k+l \neq 2n$ .

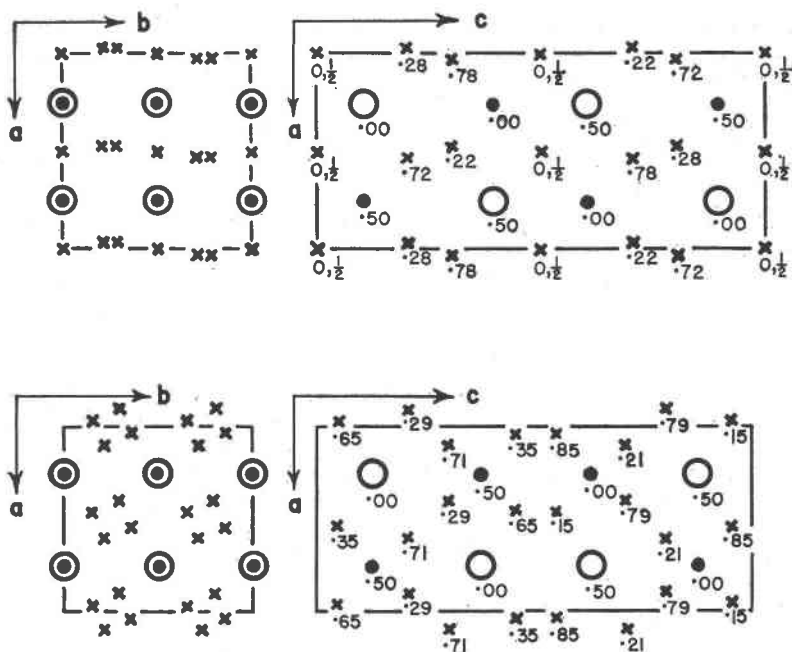

FIG. 1. *a* (top), Pucherite,  $\text{BiVO}_4$ ; *b* (bottom), tetragonal  $\text{BiAsO}_4$  (after Mooney, 1948). Large open circles, Bi; solid circles, V or As; crosses, O.

### DISCUSSION

Although it is difficult to draw reliable conclusions about the oxygen coordination around the metal ions until the parameters of the oxygens in general positions are fixed more accurately, the preliminary structure indicates that both bismuth and vanadium are present in pucherite as tetravalent ions with the oxygen ions grouped somewhat closer around the smaller vanadium ions than they are around the larger bismuth ions.

The pucherite structure may be compared directly with that proposed by Mooney (1948) for tetragonal bismuth arsenate,  $\text{BiAsO}_4$ . This crystal has the scheelite structure, space group  $C_{4h}^6-I4_1/a$ , with  $a=b=5.08$  Å and  $c=11.70$  Å. The axial lengths, therefore, are very close to the corresponding ones of pucherite. The cell volume of the vanadate, however, is about 7% larger than that of the arsenate in spite of the smaller ionic radius of vanadium. This suggests a somewhat more open coordination in pucherite.

The bismuth arsenate cell is shown in Fig. 1b in the same projections as those of pucherite in Fig. 1a. For purposes of comparison the origin of Mooney's cell has been shifted to  $\frac{1}{4}, 0, \frac{1}{8}$ . There is some superficial simi-

larity between the two sets of projections, particularly in the positions of the metal ions, but examination of their  $y$  coordinates in Fig. 1 shows that they form a face-centred lattice in the vanadate as against the body-centred lattice in the arsenate. This is presumably connected with the different types of oxygen coordination in the two structures. It should be mentioned, however, that tetrahedral coordination of the  $\text{AsO}_4$  groups was assumed in working out the structure of bismuth arsenate (Mooney, 1948); it was not derived from the intensity data.

## REFERENCES

- BARNES, W. H. & QURASHI, M. M. (1952): Unit cell and space group data for some vanadium minerals, *Am. Mineral.*, **37**, 407-422.
- DANA, E. S. (1947): *Textbook of Mineralogy*, ed. 4, revised by W. E. Ford, New York, p. 702. *System of Mineralogy*, vol. 2, 1951, data in personal communication from Dr. C. Frondel.
- DE JONG, W. F. & DE LANGE, J. J. (1936): X-ray study of pucherite, *Am. Mineral.*, **21**, 809.
- MOONEY, R. C. L. (1948): Crystal structure of tetragonal bismuth arsenate,  $\text{BiAsO}_4$ , *Acta Cryst.*, **1**, 163-165.